

3C SERIES

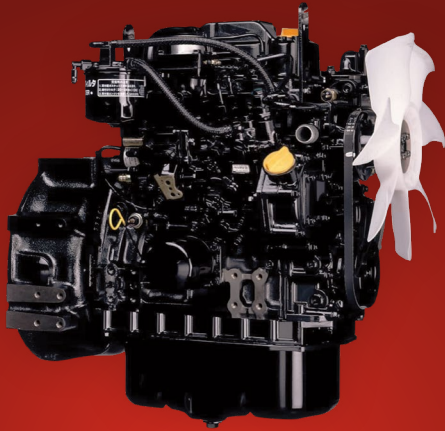

DEPENDABLE POWER

- 3CJ1** Constant Speed
11.8 HP (8.8 kW) @ 1800rpm
Variable Speed
19 HP (14.2 kW) @ 3000rpm

- 3CH1** Constant Speed
14.9 HP (11.1 kW) @ 1800rpm
Variable Speed
23.9 HP (17.8 kW) @ 3000rpm

- 3CE1** Constant Speed
21.1 HP (15.7 kW) @ 1800rpm

ISUZU
The power behind it all.™

ENGINE SPECIFICATIONS

	3CJ1	3CH1	3CE1
Displacement	1.0L	1.3L	1.6L
Cylinders	3	3	3
Cycle	4	4	4
Turbo Charger or Charged Air Cooled	Naturally Aspirated	Naturally Aspirated	Naturally Aspirated
Electrical System	Electric self-priming fuel lift pump	Electric self-priming fuel lift pump	Electric self-priming fuel lift pump
Max Torque	51.7 Nm (38.1 lb ft) @ 1900 rpm	61.6 Nm (45.1 lb ft) @ 2000 rpm	83.2 Nm (61.4 lb ft) @ 1800 rpm
2 Year / 2000 Hour Limited Warranty*	Yes	Yes	Yes
Cooled EGR	No	No	No
SAE Housing Options	SAE 5 flywheel housing or flat plate	SAE 5 flywheel housing or flat plate	SAE 5 flywheel housing or flat plate
Gear Case PTO	N/A	N/A	N/A
Glow Plug Starting Aid	Yes	Yes	Yes
Aftertreatment	No	No	No

*See your authorized Isuzu representative for warranty details.

ENGINE PERFORMANCE CURVES

3CJ1

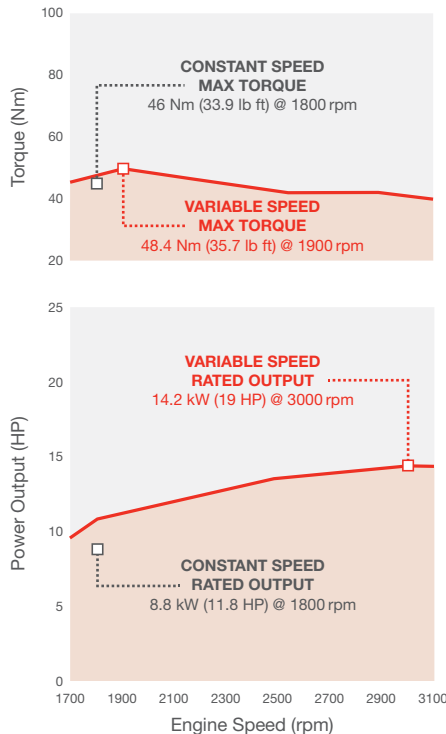

3CH1/3CE1

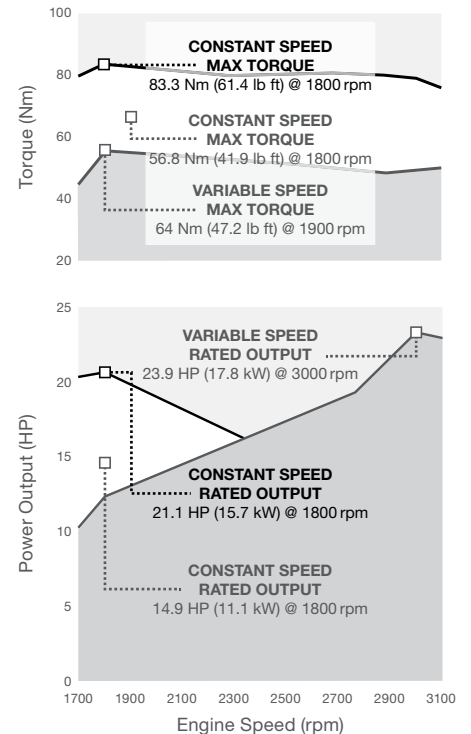



ISUZU REDTECH™

Reliable | Eco-friendly | Durable | Technologically Advanced

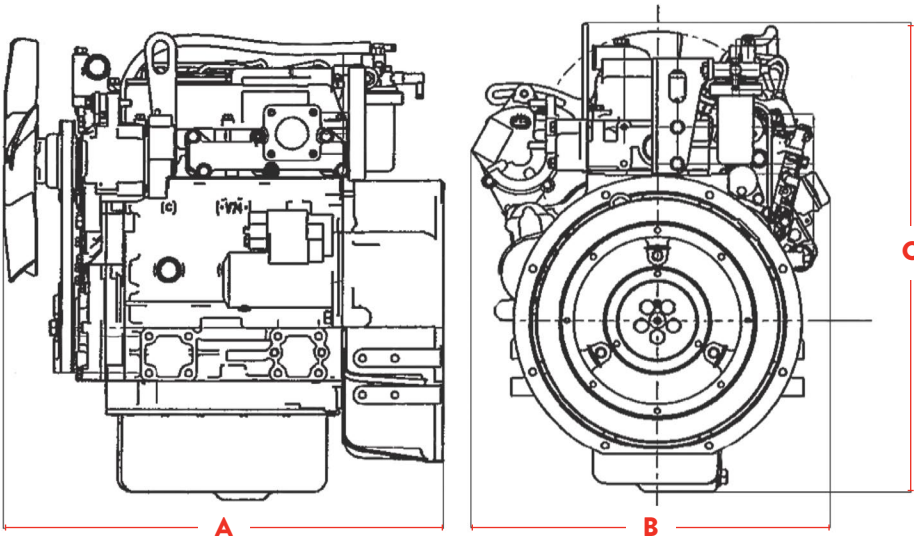

ENGINE DIMENSIONS

3CJ1

3CH1

3CE1

A - Length	21.9" (556mm)	22.6" (574mm)	24.4" (619mm)
B - Width	16.1" (409mm)	17.4" (442mm)	20.8" (528mm)
C - Height	21.9" (557mm)	23.1" (586mm)	26.9" (682mm)
Dry Weight	110kg (242.5lbs)	148kg (326.3lbs)	158kg (348.3lbs)

APPLICATIONS



Aerial Work Platform



Construction Machinery



Hydraulic Pump



Agricultural



Forest Machinery



Irrigation



Air Compressor



General Industrial



Water Pump



Asphalt Paver



Generator

CERTIFICATIONS

US | EPA - TIER 4

EU | Stage V¹

STANDARD FEATURES

- Electric & self-priming fuel lift pump
- Glow plug starting aid
- Flywheel housings: #5 or flat plate
- 2-year / 2,000-hour warranty²
- 250-hour or 500-hour oil drain & service interval

AVAILABLE OPTIONS

- Side or bottom drain oil pan
- SAE A Gear Case PTO
- Cooling packages
- Air cleaners
- Meter board and wire harness
- Engine mounting
- Weather and sound-proofing enclosure

POWER UNITS AVAILABLE

- Standard
- Custom

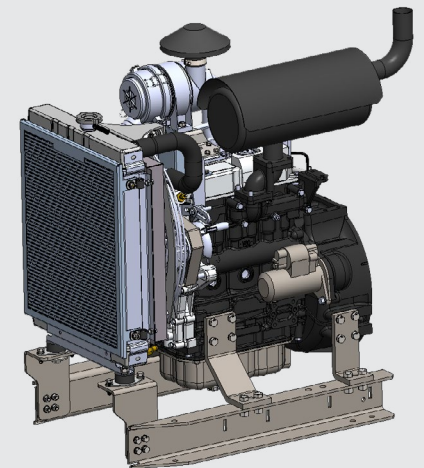

Isuzu Motors America, LLC
 46401 Commerce Center Drive
 Plymouth, Michigan 48170
 Phone: 734.582.9470
 isuzuengines.com

¹ See your authorized Isuzu representative for certified configurations.

² See your authorized Isuzu representative for warranty details.